

**F2010A020****HCCI-COMBUSTION IN THE Z ENGINE**

Author: Timo Janhunen

Aumet Oy, Leankuja 4, 07230, Finland,

Keywords: efficiency, emissions, diesel engine, combustion, HCCI

**ABSTRACT**

The most common car engine is a 4-cylinder 4-stroke engine. The car manufacturers have a great pressure to lower the cost of the cars and this deals also with the engines. The challenges are the coming new emission norms ( for example EURO-6) and also the custom acceptance, because of the fact, that the car drives are used to the 4-cylinder engine and they want to have the same driving fun also from the new engines.

A 2-cylinder 2-stroke engine has the same power output and torque as a 4-cylinder 4-stroke engine and thus it offers the same driving fun. Equal balancing is easy to make without some big additional costs, if the gas exchange of the engine is made by using poppet valves and camshafts. As there are only about 50% of the moving parts in the engine, its acceleration is even better than by a 4-cylinder engine.

One of the latest development in 2-stroke engines is the Z engine, having the compression partially transferred outside of the working cylinders. This offers new thermo dynamical possibilities to adjust the working cycle and the combustion. As there are methods to control the temperature at TDC, a HCCI-combustion is possible in the Z engine at all loads. This lowers significant the cost of the engine, as no urea injection, or NOx catalyst is needed to pass the coming EURO-6 emission norm. The cost of the Z engine is lower also because of the fact that it has only 2 working cylinders instead of 4. These unique features lower the production costs of the Z engine about 30% compared to an equal 4-cylinder 4-stroke engine.

In 1999, Aumet Oy began to research this 2-stroke car diesel engine, called the Z engine, in co-operation with the Internal Combustion Engine Laboratory at the Helsinki University of Technology (HUT) and the Energy Technology Department at the Lappeenranta University of Technology (LUT). So far, three master's theses, two SAE Papers and three Fisita Papers have been completed on the subject. Modern simulation tools, such as Star CD, GT-Power, Diesel RK and Chemkin have been used. Aumet's research project was a part of the Finnish Engine Technology Programme, ProMotor, and it was supported by the National Technology Agency Finland, TEKES. The prototype engine made its first start in December 2004 and testing of the engine has been made two years in a test bench at VTT (Technical Research Centre of Finland). The Z engine has until now got seven international patents, several are pending and Aumet Oy has got recently the Euro patent in February 2009

In the HCCI combustion simulation of the Z engine, a 4-dimensional ignition delay map, calculated with Chemkin and integrated in Diesel RK, has been used. The simulations and tests with the test engine show that the Z engine has a very good efficiency, especially at part load. A HCCI-combustion at all loads is possible in the Z engine, with lambda about 1,2-1,5 and EGR-rate 10-40%, depending of the load. The TDC-temperature at part load is about 800 K and at full load (bmep 30 bar) about 700 K. The HCCI- ignition, triggered with a pre chamber spark plug (Multitorch), occurs at full load between 15° - 20° ATDC and this limits the pressure and maximal temperature. NOx values are very low as the maximal temperature at full load is about 1900 K because of the low starting temperature of the combustion, intern EGR and the expansion during the combustion.

## TECHNICAL PAPER

### The Z process

The Z engine contains several new features. It is a combination of a 4-stroke and a 2-stroke engine. The intake and the exhaust poppet valves are placed into the cylinder head. The Z engine doesn't have many similarities with 2-stroke engines. There is no mixing of the new charge with exhaust gas or loss of the fresh air to the exhaust channel. Because the Z engine doesn't utilize the port scavenging, there are no emissions caused by lubricants getting into the cylinder from the scavenging ports and no excessive wear of the piston ring.

The main principle of the Z engine is removing a part of the compression from the work cylinder to external compressors. The external compression is done with a 2-stage compressor set. The first-stage compressor is a turbo charger. The second-stage compressor is a piston compressor that is integrated into the engine. As the pressure level in the piston compressor is only about 10% of the pressure level in the working cylinder, the compressor can be very light constructed and it is economical to produce. The temperature in the piston compressor can be kept very low compared to that of the working cylinder. There is an adjustable intercooler after each compressor stage for the temperature control. The inter-cooling is adjusted by using bypass valves. The pressure level of the intake air after the external compression varies from 4 to 15 bar.

The combustion air is conducted into the work cylinder through the poppet valves. The intake begins when the piston is approaching the top dead centre (for example around 60° BTDC) and the intake valves are open only about 15-20° on the crankshaft. This fast intake is possible because of the high intake manifold pressure. The final compression takes place in the work cylinder. The fuel is injected into the cylinder. The combustion is followed by the expansion stroke. The exhaust valves are opened before the bottom dead centre as in the 4-stroke engines. During the upward stroke, the piston pushes most of the combustion products out from the cylinder until the exhaust closes and the intake opens. Thus an intern EGR is possible.

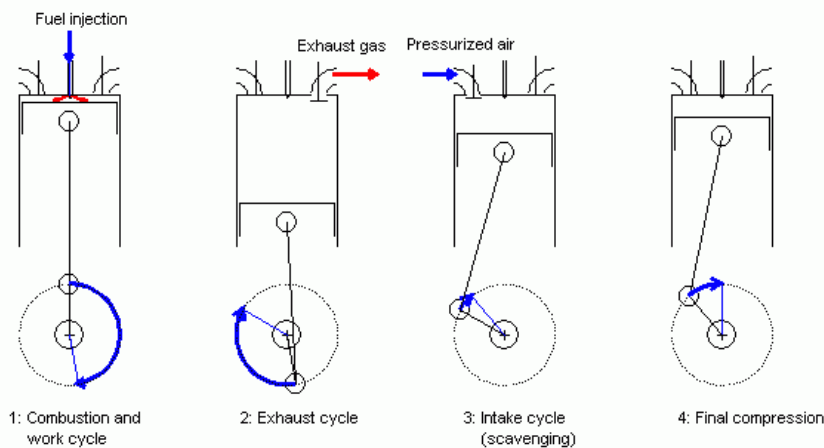

Figure 1: The process in the work cylinder

The main features of the Z engine are: 4-stroke work cycle at every stroke of each piston, fully valve controlled gas exchange (SAE 2004-01-0607), diesel or otto engine (SAE 2003-01-3211), turbo charger + supercharger (piston compressor), 2 cylinder Z engine is equal

to a 4 cylinder 4-stroke engine, low emissions, as HCCI combustion, low fuel consumption, especially at part load, excellent transient behaviour, because of the supercharger, high bmep, high downsizing degree, high mechanical efficiency as less cylinders.

The gas exchange of the Z engine has following features: gas exchange is controlled with poppet valves, exhaust valve opens  $60^\circ$  BBDC, exhaust valve closes  $120^\circ$  ABDC, intake valve opens  $60^\circ$  BTDC, intake valve closed  $45^\circ$  BTDC, intake pressure : 4-15 bar, the velocity of the intake gas: 300-500m/s, hot, intern EGR (10-40%) acts as an intern heat exchanger, hot, active radicals in the intern EGR, no problems with contamination or corrosion, as intern EGR, no losses of the intake gas to the exhaust channel, as no overlapping of the intake and exhaust valves, pulse turbo charger, VTG, intercooler after the turbo charger, intercooler after the piston compressor, with a by pass valve, variable timing of the intake and the exhaust, in synchronous, electric heater in the intake channel for the cold start.

The fuel injection of the Z engine has following features: fuel injection during  $110^\circ$ - $120^\circ$  ABDC, when exhaust valves close, injection pressure: 200-700 bar, low parasite losses, injection duration  $5^\circ$ - $12^\circ$ , fixed start point of the injection, high injection rate nozzle, hollow cone spray (SAE 980533), small spray penetration, small droplets ( a diploma work is going on, based on SAE 1999-01-0183), partial fuel reforming, as injection to the hot exhaust gases, rapid fuel evaporation, as high temperature and low pressure during the injection (special transient area), fuel evaporation energy from EGR: higher heat value of the fuel, gas temperature during the start of the injection: 700-800 K, gas pressure during the start of the injection: 1,5 – 2,5 bar, no swirl during the injection, no wall wetting, temperature drop of the gas in the cylinder during the injection :200-400 K, high turbulence after the injection, as intake valves open, long mixing time before the ignition,  $60$ - $70^\circ$ : homogenous mixture.

The compression of the Z engine has following features: the mechanical compression ration of the engine: 14-15:1, compression ratio: IVC – TDC = 3:1 – 5:1, adjustable with the valve timing (secondary compression in the work cylinder), short compression time; low amount of heath transfer, low compression temperature, as high inter cooling rate, low compression temperature, as fuel evaporation before the final compression, compression temperature at TDC, part load = 800 K, compression temperature at TDC, full load = 700 K, **the compression temperature lowers when the load increases**, lower compression pressure, as lower gas temperature, compression temperature can be controlled with the intercooler, compression temperature can be controlled with the amount of EGR, compression pressure can be controlled with the pressure ratio of the piston compressor, compression pressure can be controlled with the intake timing, first pre compression in the turbo charger: pressure ratio= 1,3-4, second pre compression in the piston compressor: pressure ratio=2,5-4, piston compressor well cooled: smaller compression work, high efficiency in the piston compressor, as poppet valves.

The ignition in the Z engine has following features: HCCI- ignition, spark assisted (SAE 2005-01-3732), ignition can be controlled with the temperature at TDC, ignition can be controlled with the pressure at TDC, ignition can be controlled with valve timing (overlap , iEGR), ignition can be controlled with hot, active radicals in iEGR, ignition can be controlled with lambda, ignition can be controlled with the injection timing, ignition can be controlled with injection amount ( iEGR, very rapid response), ignition can be triggered with a pre chamber spark plug (Multitorch) (SAE 2002-01-2867), ignition can be assisted with a glow plug, late ignition: smaller heat losses, exact ignition timing possible, Chemkin used in calculations, 2% of the fuel energy enough to trigger HCCI – ignition.

The combustion of the Z engine has following features: HCCI – combustion at all loads, as all the fuel has evaporated and mixed with the gas in the cylinder before the ignition,  $\lambda$ : 1,2 – 1,5, EGR=10-40%, late combustion: smaller  $dp/d^\circ$ , late combustion: smaller  $p$  max, high bmep, as low  $\lambda$ , low  $T_{compr}$  and low amount of EGR, rapid combustion: high efficiency, smaller heat losses, combustion duration 10-15°, low NOx and particulates, as a HCCI combustion, turbulence during the combustion: good combustion efficiency, particulates, CO and HC oxidate, low start temperature of the combustion and EGR limit  $T_{max}$ , maximum temperature 1900 K, higher than by normal HCCI: particulates, CO and HC oxidate

The expansion of the Z engine has following features: expansion during the combustion, turbulence during the expansion: particulates, CO and HC oxidate, high temperature (more than 1500 K) long time enough in order to oxidate particulates, CO and HC, inbuilt Atkinson cycle, inbuilt variable compression ration, small heat losses as expansion at every cycle (2-stroker)

The exhaust of the Z engine has following features: exhaust from 60° BBDC to 120° ABDC, pulse turbo charger, pulses:  $2 \times 180^\circ = 360^\circ$ , low backpressure in the pulse turbo charger (Watson, Janota), exhaust gases hot enough for 3-way catalyst.

The geometric compression ratio does not define the maximum compression temperature and pressure in the Z engine. Rather, it defines the maximum power by fixing the compression volume. The compression volume with the maximum allowed pressure and the minimum possible (auto ignition, etc.) temperature gives the mass of the combustion air and thereby defines the maximum power output. The geometric compression ratio is, for example 15, depending on the application.

Because a part of the compression occurs externally, the final compression temperature and pressure are not tied together in the Z engine. This gives the engine designer more parameters with which to optimize the engine for different load, speed and environment situations. The amount of the charge air can be altered by changing the valve timing and by controlling the intake temperature and pressure. This makes it possible to control, for example, the air/fuel equivalence ratio in a compression ignition engine.

The valve timing affects the portion of the compression done in the work cylinder and also to the intern EGR. It is useful to shift more compression to the work cylinder for example at part loads. The turbo charger in the Z-engine can use all the available exhaust gas energy at all load conditions and thus no waist gate is needed. This improves the efficiency of the engine.

The Z engine can also utilize the Otto cycle. The knock phenomenon, found at high geometrical compression ratios and pressures when using gasoline fuel, can be avoided, because the compression temperature can be controlled separately. A higher overall efficiency could be gained because of the higher compression ratio and better controllability especially at part loads. The Z-engine utilizes Atkinson cycle and it has an inbuilt variable compression ration.

## THE INTAKE FLOW

The theoretical flow behaviour in the valves can be seen in Figure 2. The pressure difference has been received from a simulation of the engine. The required ratio between the exit area of

the valves and the throat (at the inner seat) area has been calculated from the flow speed and the specific volume of the flow (nozzle flow). The calculated exit area/throat area ratio has been calculated from the valve lift data and the valve dimensions.

The intern exhaust gas re circulation (iEGR) rate was 20% and the exhaust gas was not rotating at the beginning of the gas exchange. The flow coefficient of the intake valves is high, about 0,9, because the flow is a nozzle flow .

The temperature of the intake air lowers about 30 – 50 K because of the very high intake velocity.

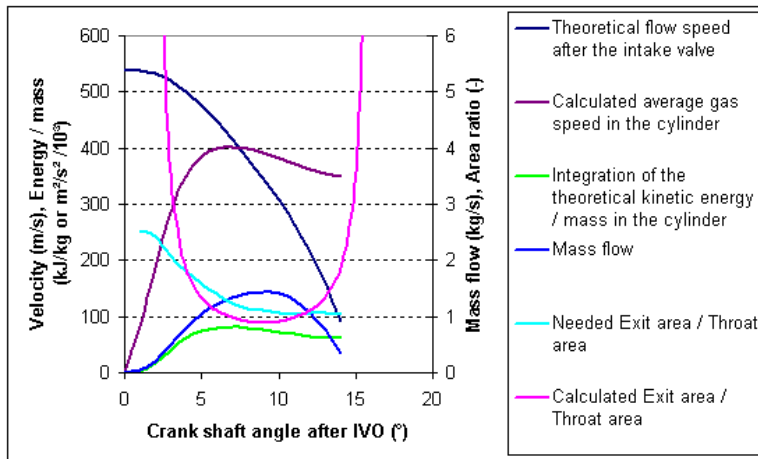

Figure 2: The theoretical valve flow

## THE FUEL INJECTION

The fuel injector can have a hollow cone shape, forming a pintle nozzle injector like that used in gasoline injection systems. This type of injector has been used also in the swirl-chamber diesel-combustion systems. For example, the CAV Microjector, Figure 3, is an injector of this type, which was used in some USA-made swirl-chamber engines in the 80s.

These type of injectors have a good atomisation without needing a high fuel pressure. This makes the fuel injection system easier to manufacture and more cost effective. This kind of nozzle has no sac volume and there are no hydrocarbon emissions caused by fuel evaporation from the sac volume.

The low injection pressure, only 200 - 700 bar, increases the efficiency of the engine by 1,5-2% compared to engines using 1600-2000 bar. This type of a low pressure injector is ideal at cylinder pressures up to 3 bar, according to many research papers (for example Dr. Reitz). The injection of the fuel occurs at this pressure in the Z-engine, between 70 – 60 deg. BTDC.

The small flow gap in the injector nozzle, about 0,05 mm and the high flow area, about 0,5 sq. mm /nozzle, makes a good atomisation and a short injection period possible. Another low pressure injector type for HCCI combustion is described in SAE-paper 1999-01-0183.

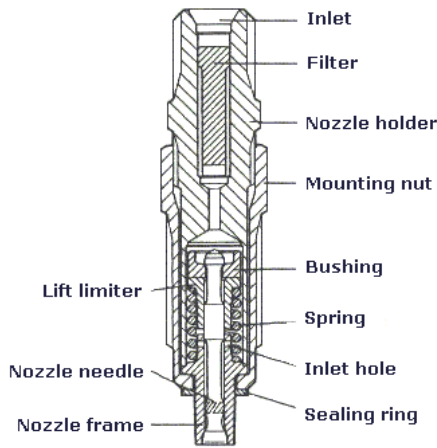

Figure 3: CAV Microjector injector

The NO<sub>x</sub> measurements of the Z combustion was in made in the brake in December 2006 at VTT (Technical Research Centre of Finland) . At part load NO<sub>x</sub> was 0,8 g/kWh and the efficiency of the Z engine was 35%

### The Z-HCCI combustion

In order to reduce still NO<sub>x</sub>, it was developed a new type of combustion, a swirl less late HCCI combustion. The fuel injection of for HCCI combustion occurs at about 70 - 60° BTDC, when the temperature is about 700 - 800K (depending of the load) and the pressure is about 1,5-2,5 bar. This rapid transient area of the gas exchange of the Z engine makes a very rapid evaporation of the droplets possible. The pressure in the cylinder of a conventional diesel engine is in this situation about 10 bar.

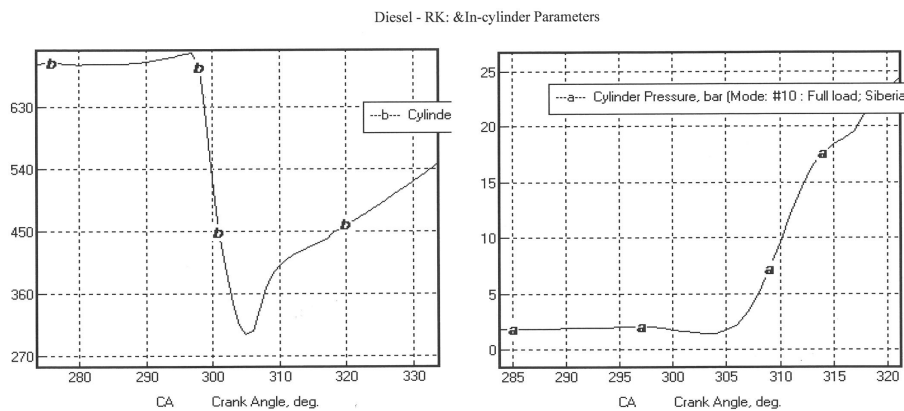

Figure 4: The temperature(K)- and pressure(bar) curves between 80°-40° BTDC

After the fuel injection the intake valves open and the high velocity gas flow creates a high turbulence in the cylinder. This makes a rapid mixing and HCCI combustion possible, as well as the long mixing time, 60-70°, before the ignition.

The special pre chamber spark plug ignition activates the cool flame at about TDC and it acts as an amplifier to ignite the HCCI mixture at about 0-20 ° ATDC.

The low pressure fuel injection makes a late HCCI-combustion possible, as the compression temperature at TDC do not exceed 800 K and thus the cool flame don't appear automatically and the mixture don't self ignite. By this way it is possible to trigger the ignition of the HCCI-mixture at 0-20° ATDC. From this point the down wards moving piston lowers the pressure- and temperature rise during the HCCI-combustion.

Diesel - RK: & Fuel Injection and Heat Release

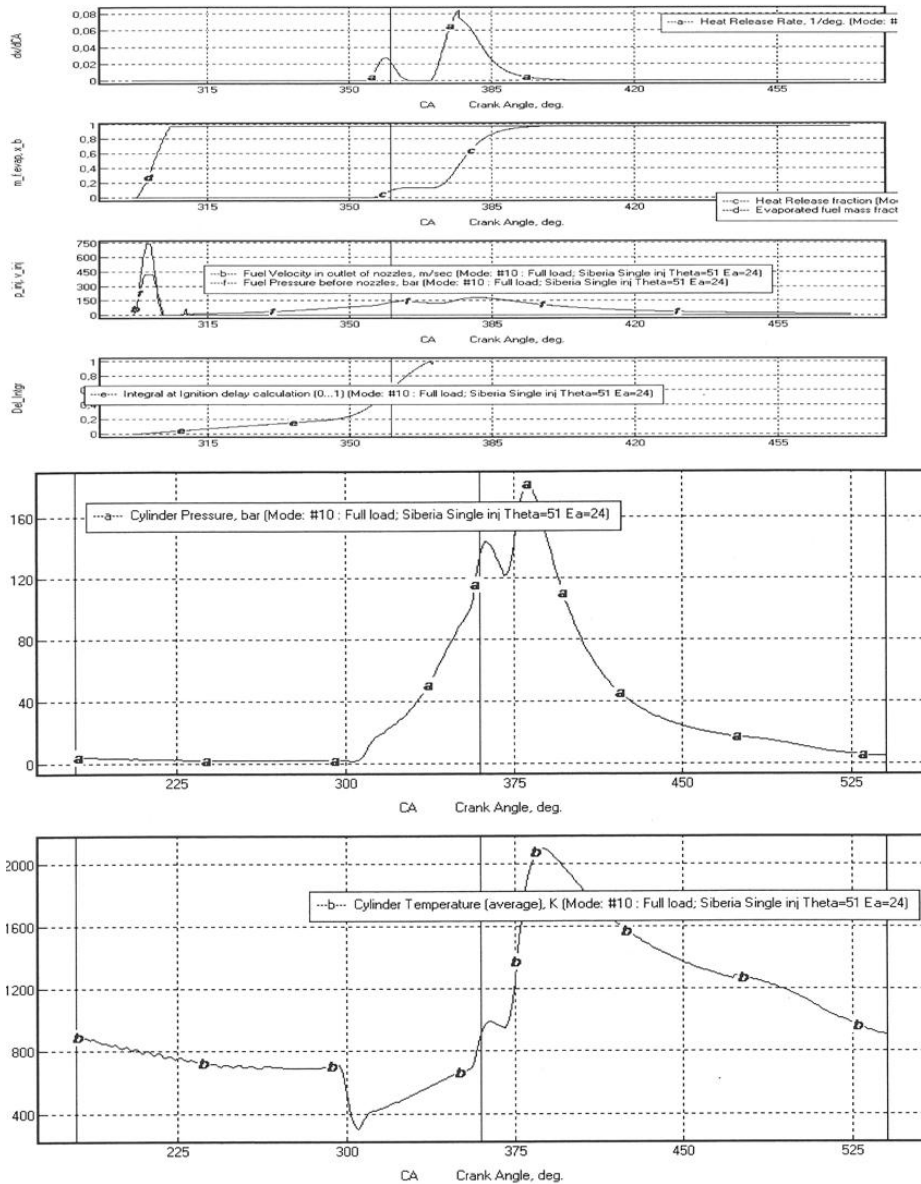

Figure 5 Simulation results with Diesel RK

The pressure rise in HCCI combustion is at bmep 29, about 7,5 bar/deg, lambda = 1,2 and EGR = 15%. Note the “twin peak” in the pressure curve. The ignition delay is calculated with Chemkin.

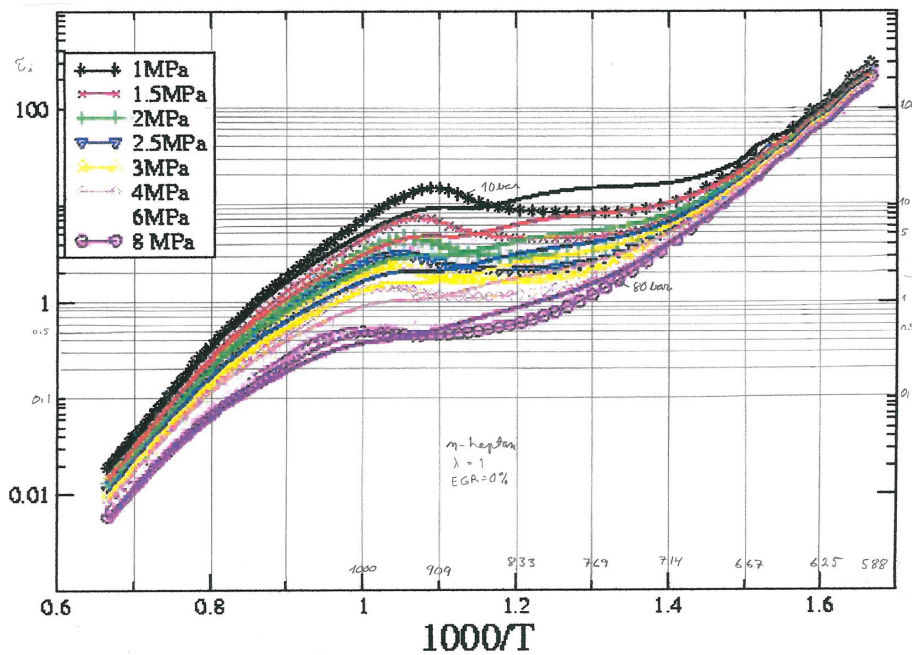

Figure 6: The ignition delay curve (ms) of HCCI mixture.

In order to be able to understand, how to define the exact ignition point in the Z engine, it is necessary to study the ignition delay curves of n-pentane, where variables are temperature and pressure. Thus we can first see the path of the mixture, when the piston moves from (for example)  $-40$  deg to TDC. If the rotation speed is 1700 rpm, so 10 deg=1 ms. The pressure- and temperature values can be taken from fig.5 starting from  $320^\circ$ . As lambda in the Z engine is for example 1,2, this is equal to about 2500 J/g air. At TDC conditions:  $p=100$  bar,  $T = 700$ K, the needed energy to rise the temperature of the mixture for example 50K to ensure the exact ignition point, is about 50 J, or 2% of the energy of the mixture. The volume of the pre chamber spark plug can be chosen to be this 2% According to the curves in Fig. 6, this change shortens the ignition delay from 3 ms to 0,8 ms. This very high sensitivity of the ignition point makes it possible to define the main ignition very exact by igniting first about 2 % of the fuel in the pre chamber spark plug. This ignition activates the cool flame and thus it is possible to use the cool flame as an amplifier in order to trigger the main ignition at about 0-20 deg ATDC. The down wards moving piston limits the pressure rise and makes this unique combustion system possible. This type hybrid combustion is also called spark-assisted HCCI combustion in research papers (for example SAE-2006-01-0418 and Ignition Control for HCCI, agreement 9285, OAK RIDGE 2008)

As the HCCI combustion is rapid, the weight point of the combustion is not far from TDC and thus the efficiency of the engine stays high. This also lowers the heat losses close to TDC during the HCCI-combustion. The amount of the intern EGR is easy to adjust, for example by throttling the exhaust channel.

## The Z engine

The Z-HCCI-combustion and the Z engine offer following advantages:

- high efficiency, especially at part loads
- excellent transient behaviour
- work at every stroke of the piston
- equal to 4-cyl.,4-stroke turbo charged diesel engine
- high bmep
- very light and small engine
- 30% lower manufacturing costs than by equal 4-cyl. 4-stroke turbo charged engine
- low injection pressure, about 200-700 bar
- low heat losses, especially at TDC-area, as late HCCI combustion
- good mechanical efficiency, as less moving parts
- low EGR, about 10-40%
- easy ignition control of the HCCI-combustion
- low combustion noise, even at full load, as not too high pressure rise speed
- low particle emissions
- NOx 0,05 g/kWh

The Z-engine has got the Euro Patent in February 2009.

The test of this new combustion system shall be performed during 2010 at VTT in Finland. The Z engine has been simulated with a special modification of the simulation program Diesel RK, made by Dr. Andrey Kuleshov.

### Z-ENGINE, AN ECONOMICAL ALTERNATIVE TO A HYBRID SYSTEM

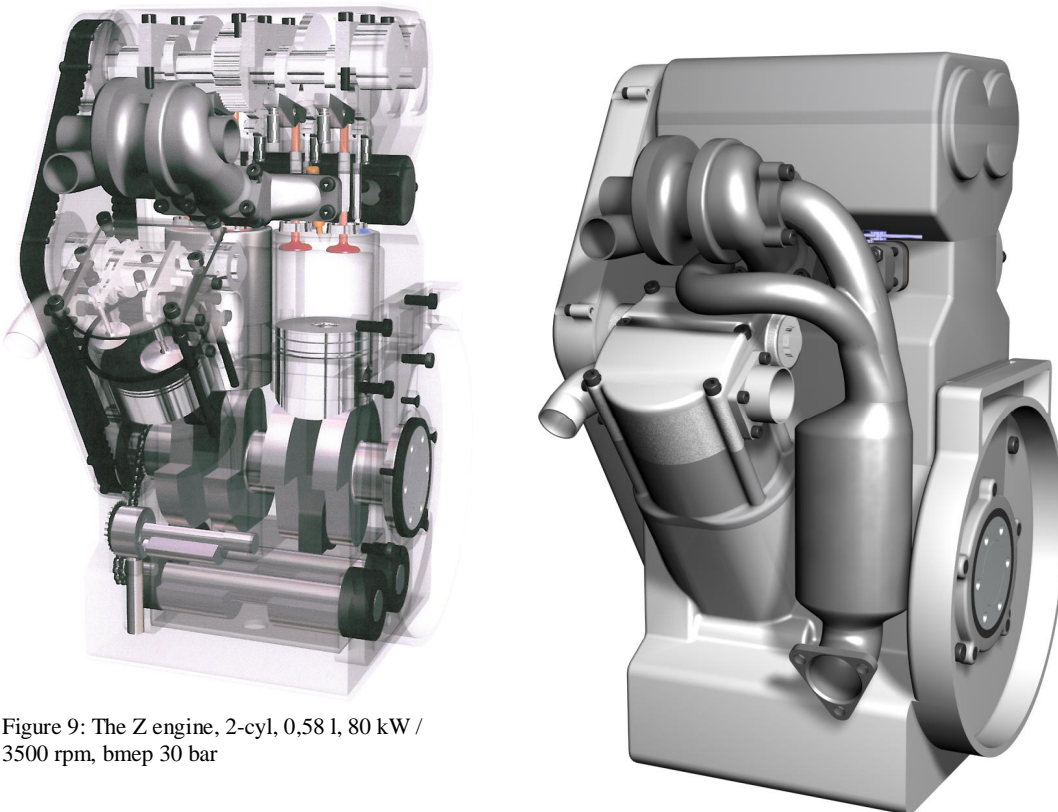

Figure 9: The Z engine, 2-cyl, 0,58 l, 80 kW / 3500 rpm, bmep 30 bar

## References:

- A Study of Homogeneous Ignition and Combustion Processes in Ci, Si and HCCI Engine Systems, Jincal Zheng, Doctor Thesis 2005, pages 137-221
- Autoignition Initiation and Development of n-heptane HCCI Combustion Assisted by Inlet Air Heating, Internal EGR or Spark Discharge: an Optical Investigation SAE 2006-01-3273
- Direct Modelling of Auto-Ignition and Flame Propagation of N-heptane-Air Mixtures at HCCI Conditions by Using Dynamic Multi-Timescale Method AIAA 2010-606
- Downsizing bei Verbrennungsmotoren, Golloch, 2005
- Global Combustion Responses of Practical Hydrocarbon Fuels: n-Heptane, iso-Octane, n-Decane, n-Dodecane and Ethylene, Kamal Kumar, Doctor Theses, 2006
- Modeling an Experimental Study of an HCCI Engine for Combustion Timing Control, Mahdri Shahbakhti, Doctor Thesis, 2009
- Control of the Start of HCCI Combustion by Pulsed Flame Jet, SAE 2002-01-2867
- Investigations on Pre-Chamber Spark Plug with Pilot Injection, SAE 2007-01-0479
- Advances in Diesel Engine Combustion: Split Combustion, SAE 2007-01-0178
- Adaptive Injection Strategies (AIS) for Ultra-Low Emissions Diesel Engines, DEER 2007
- Approaches to Solve Problems of the Premixed Lean Diesel Combustion SAE 1999-01-0183
- Experimentelle und theoretische Untersuchung homogener und teilhomogener Dieselmotoren, Stuttgart 2007
- Zum Verhalten des Dieseleinspritzstrahles in einem Luftwirbel, Graz 1977
- Über die Dieselmotoren bei Einspritzung aus dem Zentrum eines Luftwirbels, Graz 1977
- A Study of NO Reduction Caused by Thermal Cracking Hydrocarbons during Rich Diesel Combustion. JSME International Journal No 2, 2006, Noge, Kidoguchi, Miwa
- Sami Nyysönen, Lappeenranta 2001: Optimisation of Thermodynamics and Flow Mechanism of a new type 2-stroke Engine, Supervisor Prof. Jaakko Larjola, Lappeenranta University of Technology.
- Sami Hörkkö, Espoo 2002: Preconditions for Fuel Ignition and Combustion in a New Type Diesel Engine, Supervisor Prof. D.Sc. (Tech.) Martti Larmi, Helsinki University of Technology.
- Tore Grönlund, Espoo 2003: Valve Train of a New Type Engine, Supervisor Prof. D.Sc. (Tech.) Martti Larmi, Helsinki University of Technology.
- Larmi M., Tiainen T., Saarinen A., Grönlund T.: "Novel two-stroke engine concept, feasibility study", SAE 2003-01-3211, Helsinki University of Technology.:
- Larmi M., Grönlund T.: "Valve train design for a new gas exchange process" SAE 2004-01-0607, Helsinki University of Technology.

Formatted: Bullets and Numbering